



# Streetbox

Aluminum outdoor cabinets resistant to weather conditions



Outside

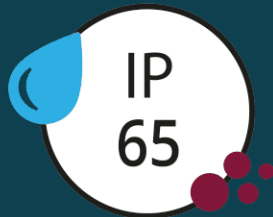

maximum  
IP 65

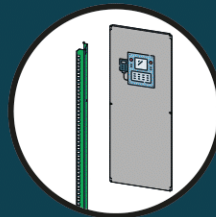

19" rack or disc  
assembly

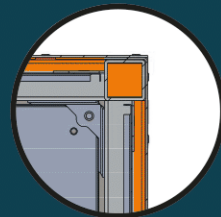

Double sheathing  
Outside



# STREETBOX

Appearance, durability and device protection



**Application:** The STREETBOX series are outdoor distribution cabinets made of powder-coated aluminum. Double-layer walls, a high degree of protection and electrostatic painting provide optimal protection for the devices installed inside.

Side walls, doors and roof are made of 2 mm aluminum sheet. Gravitational ventilation, provided by ventilation openings, can be additionally supported by ventilation panels installed inside (available as an option). The design of the ventilation grilles protects the inside of the cabinet against contamination from the external environment. Thanks to unique solutions, the outer sheathing can be additionally insulated using foam or insulating mats.

The design of the cabinets enables the use of 19" or 21" rack profiles, mounting plates for the installation of electrical devices, air conditioners and heaters, additional ventilation panels and most accessories for SABAJ control cabinets. The STREETBOX model is adapted to be placed on a metal or concrete pedestal - to be purchased as an option. Standard front door. Rear or side door available as an option. Standard color RAL 7035. Other RAL colors available on special order.

## Available colours



RAL 7035\*

## I protection class



## Application



External (ALU)

## Load capacity



800 kg

## Level of security



Version one-door



Version two-door



Special order



Big resistance mechanical

## Certificates



\* Other colors available on request

# STREETBOX

## Product features

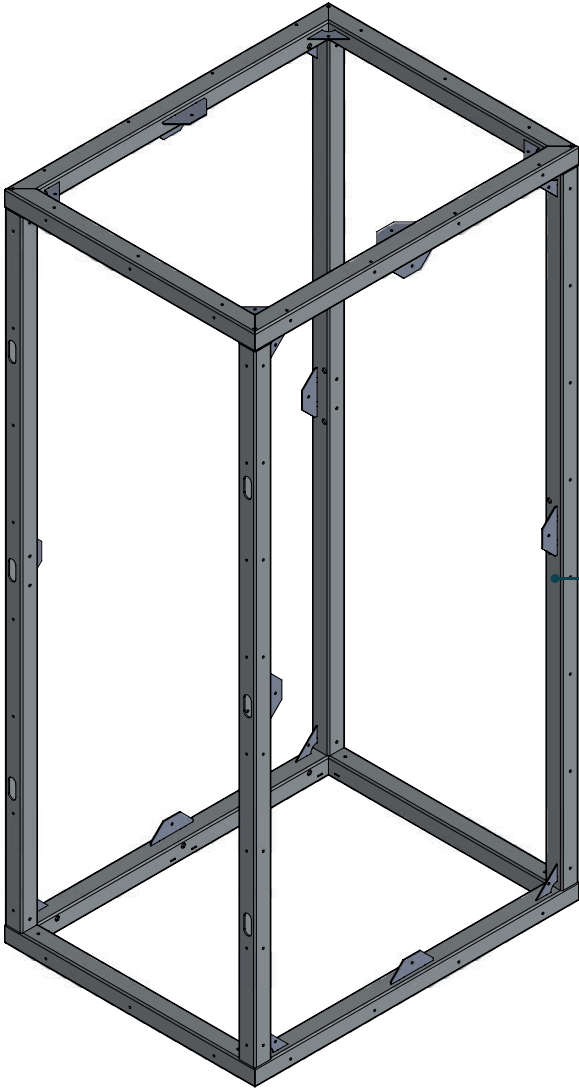

Welded frame made of aluminum profiles with a 3 mm wall



Different inserts can be used



Four locking points guarantee tight closure



The construction of the side walls and profiles enables the use of additional insulation in order to reduce the Lambda heat transfer coefficient

# STREETBOX

Ventilation and insulation

All walls allow the use of an additional insulation layer

1. Frame
2. Plinth
3. Roof cover
4. Front door
5. Insulation (optional)
6. Insulation cover
7. Rear door
8. Rear cover
9. Mounting plate
10. RACK beams
11. Ventilation panel
12. Inlet filter air

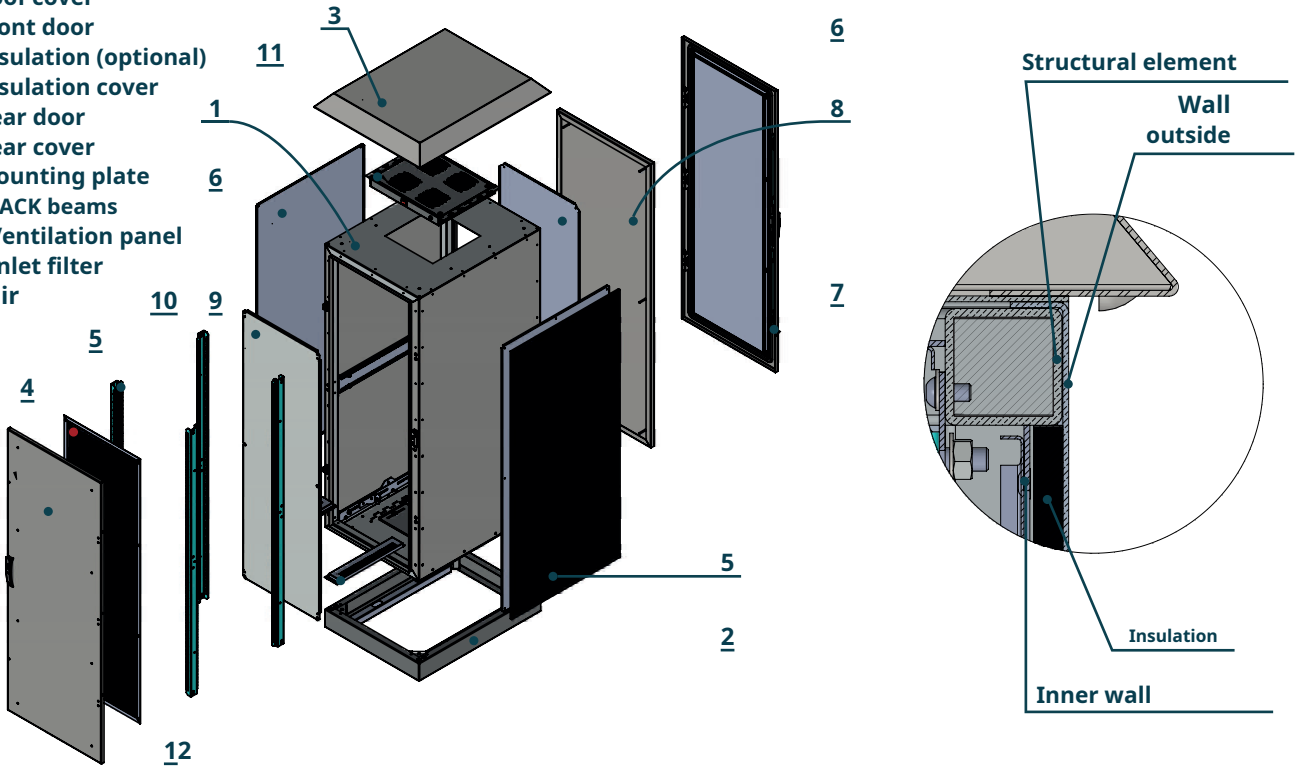

Double structure with doors, roof and side walls made of 2 mm aluminum

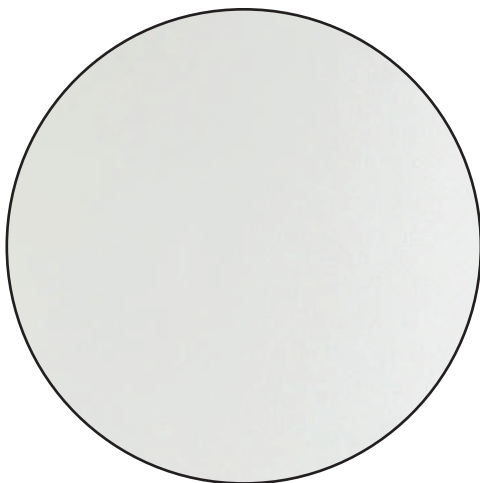

Coated with powder paint resistant to UV radiation, in RAL 7035. Other colors available after individual pricing

Thanks to the IP 55 protection level and electrostatic paint coating, the cabinet provides protection against external conditions, adversely affecting the mounted devices. Side walls, doors and roof are made of 2 mm aluminum

# STREETBOX

## Ventilation

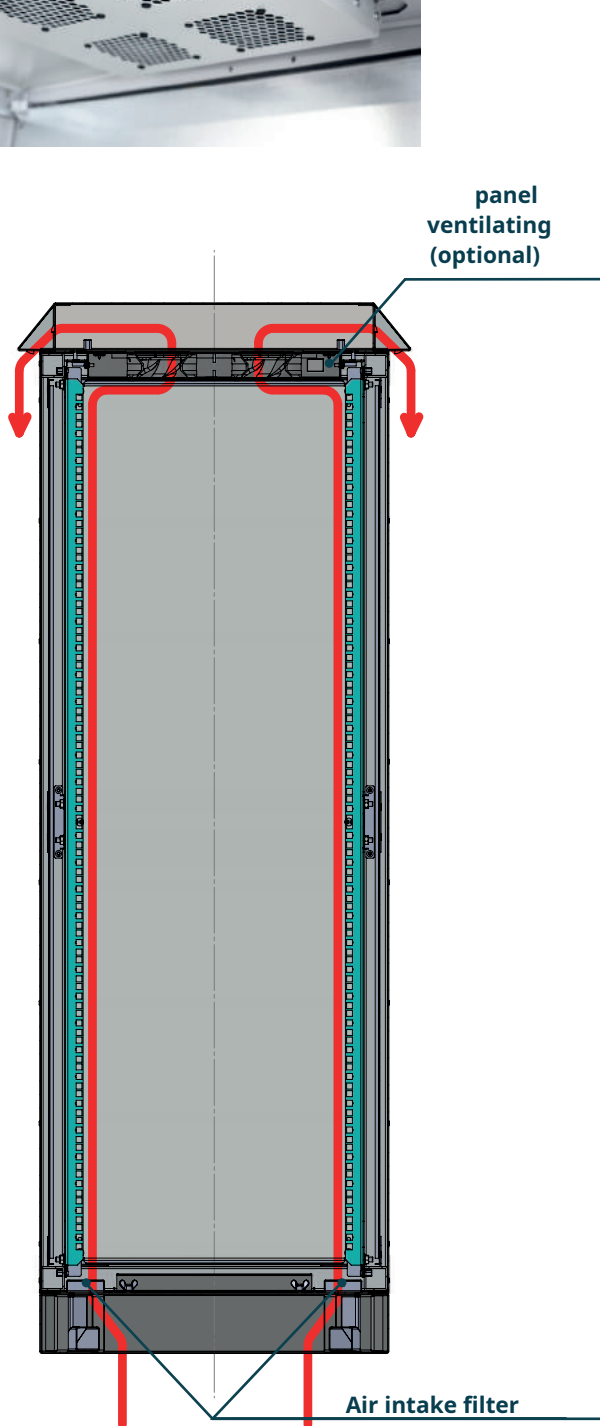

Gravitational ventilation - the possibility of support installing the ventilation panel - 19-0070

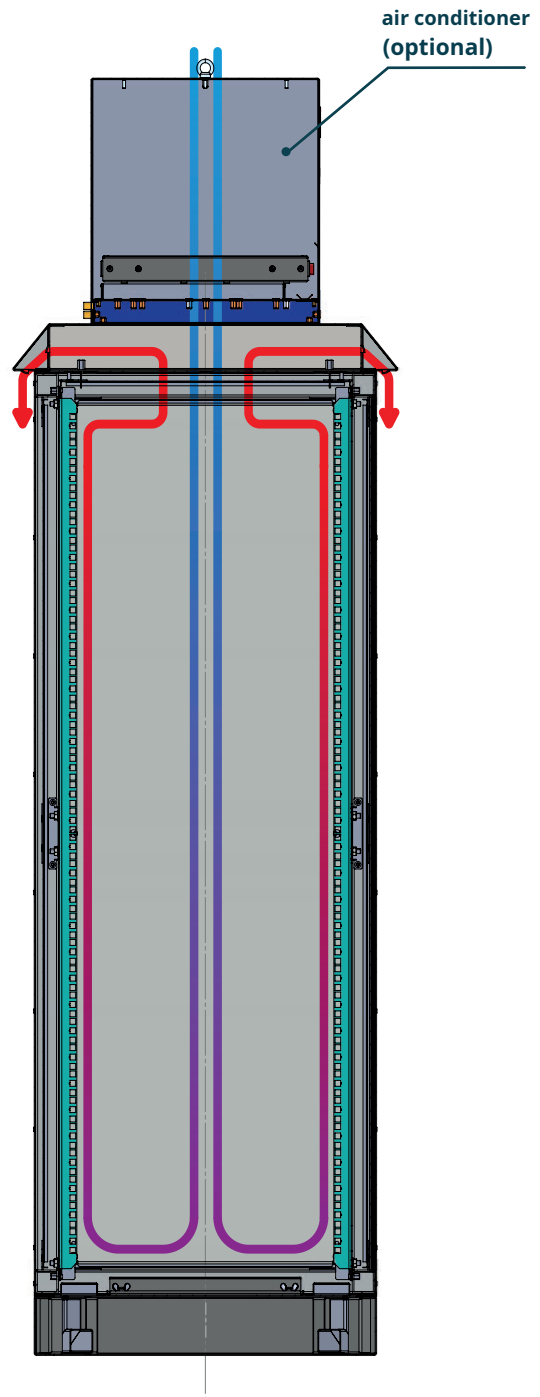

Possibility to buy and install an air conditioner to ensure perfect temperature inside the cabinet



# STREETBOX

## Example configurations

The cabinets can be equipped with numbered 19" or 21" rack bars and a 2.5 mm mounting plate. The mounting plate as well as side covers and doors can be prepared for the installation of devices such as LCD screens, switches or indicator lights

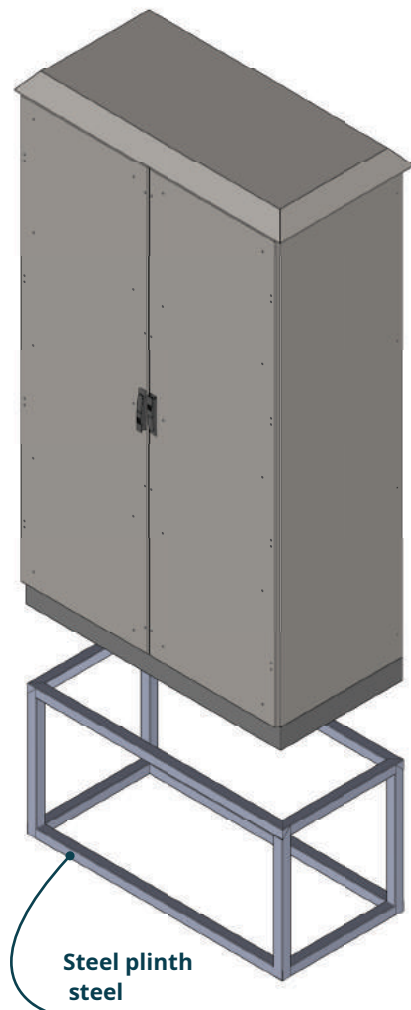
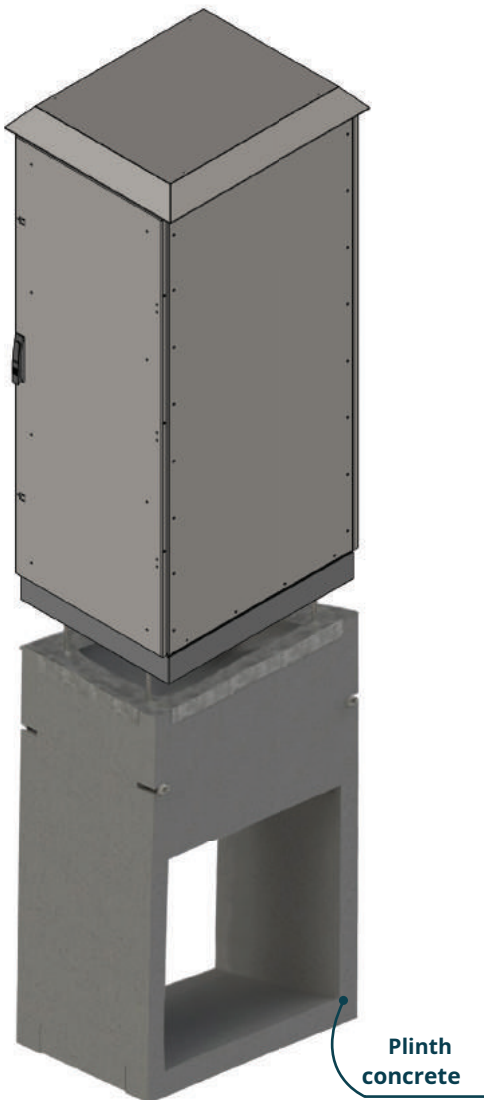
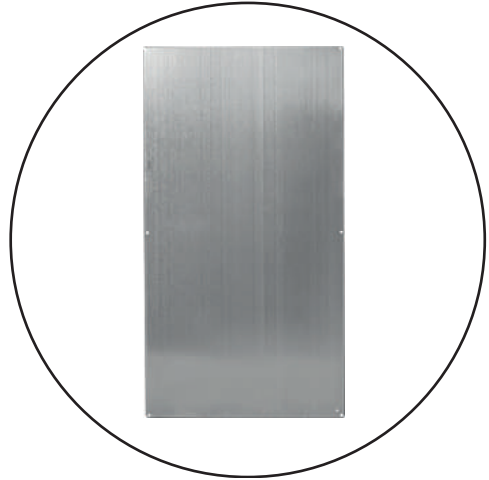

Cabinets can be placed on concrete or wet-painted stainless steel plinths, that can be embedded or buried in the ground

# STREETBOX

Dimension table

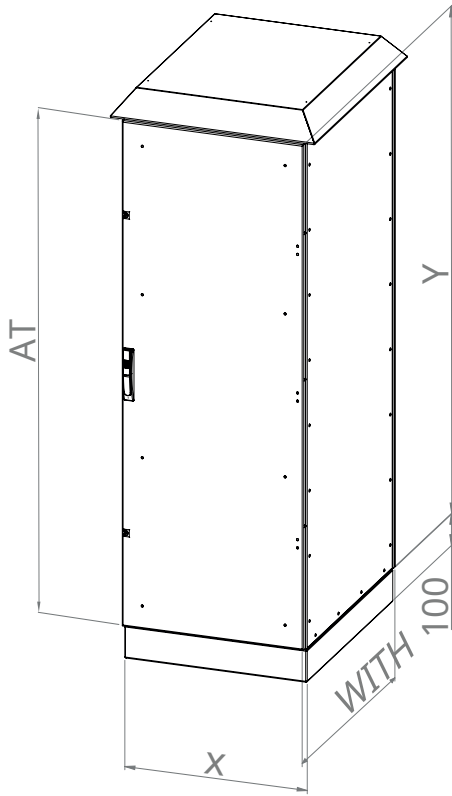

Type/No. corner.	Width X [mm]	Height Y [mm]	Depth Z [mm]	max. height usable U x 44.45mm	Version door			
STRBX-669-18U	600	940	600	18	Single			
STRBX-689-18U			800					
STRBX-889-18U	800		800					
STRBX-1269-2x18U			600			2x18	Double	
STRBX-1289-2x18U	1200	800						
STRBX-6610-21U	600	1075	600	21	Single			
STRBX-6810-21U			800					
STRBX-8810-21U	800		800					
STRBX-12610-2x21U			600			2x21	Double	
STRBX-12810-2x21U	1200		800					
STRBX-14610-2x21U	1400		600					
STRBX-14810-2x21U			800					
STRBX-6612-24U	600		1210	600	24	Single		
STRBX-6812-24U		800						
STRBX-8812-24U	800	800						
STRBX-12612-2x24U		1200		600			2x24	Double
STRBX-12812-2x24U	800							
STRBX-14612-2x24U	1400	600						
STRBX-14812-2x24U		800						
STRBX-6615-32U	600	1560		600	32	Single		
STRBX-6815-32U			800					
STRBX-8815-32U	800		800					
STRBX-12615-2x32U			1200	600			2x32	Double
STRBX-12815-2x32U	800							
STRBX-6618-38U	600		1830	600	38	Single		
STRBX-6818-38U				800				
STRBX-8818-38U	800			800				
STRBX-12618-2x38U		1200		600			2x38	Double
STRBX-12818-2x38U	800							
STRBX-6620-42U	600	2000		600	42	Single		
STRBX-6820-42U				800				
STRBX-8820-42U	800			800				
STRBX-12620-2x42U			1200	600			2x42	Double
STRBX-12820-2x42U	800							

Drawings available on the website [www.sabaj.pl](http://www.sabaj.pl)

## Plinths for STREETBOX cabinets

Concrete plinth	Fits STREETBOX cabinets the dimensions of the base	Stainless steel plinth
COK-BET-66	600x600	COK-ST-66
COK-BET-68	600x800	COK-ST-68
COK-BET-88	800x800	COK-ST-88
COK-BET-126	1200x600	COK-ST-126
COK-BET-128	1200x800	COK-ST-128
COK-BET-146	1400x600	COK-ST-146
COK-BET-148	1400x800	COK-ST-148